

THE TELETYPE;

A PRINTING ELECTRIC TELEGRAPH.

BY

FRANCIS GALTON, Esq., M.A.,

TRIN. COLL., CAMBRIDGE.

LONDON:

JOHN WEALE, 59, HIGH HOLBORN;

M^c MILLAN, CAMBRIDGE;

APPLETON AND CO., NEW YORK.

JUNE, 1850.

CONTENTS.

	PAGE
Part for enabling the weak movements of a needle to govern the movements of a heavy arm	5
Part for making the movements of the needles thus transmitted result in the printing of letters, a different letter for each different compound signal	11
Part for determining the proper movements of the needles for any given letter by touching a key	18
Part for commanding a larger number of types than there are simple signals of the needles, so that on certain pairs of signals being made, a third and a different letter shall be printed	21
Part for determining that on making certain signals no letter shall be printed, but a mechanical effect shall be produced which may be applied as we will	24
Part for regulating the movements of the paper carrier so that the printing may not be disconnected owing to the use of the above parts	24
Part for enabling communications to be carried on in cypher, so that, two machines being adjusted according to the letters of a key word, messages may be signalled and printed as usual between them, but which shall appear in cypher at every other station	26
Suggestions for increasing the number of simple signals of each needle	26

THE TELETYPE :

A PRINTING ELECTRIC TELEGRAPH.

THERE is probably no branch of practical science in which a real improvement would be hailed with greater pleasure than that of Electro Telegraphy. A great deal has been done but very much more is wanted before Telegraphs can become the common, even household, instruments of communication that they probably are destined to be.

In all those now in use the art of transmitting and interpreting messages requires much time and practice for perfect acquirement. The superior advantages of a telegraph capable of printing messages in the ordinary alphabetical characters is obvious, but it is, in the first instance, a problem of some difficulty to govern machinery of the requisite power by the extremely feeble force of which we have to dispose.

To effect this is, in part, the object of the instrument described in the following pages. By the methods here explained it is hoped that a printing electric telegraph may be constructed, simple in its mechanism, easy to be worked, and equalling in its sureness and speed any of the forms of telegraph now in use. In the Telotype (as our instrument may be termed), by merely touching a key on which any letter is marked that letter is to be printed, almost instantaneously, at the opposite end of the line.

It is well known that there are two rival ways of applying Electricity so as to cause motion at a distance; by the one we have a greater variety of signals, less force and slower action, by the other, a less variety but greater motive power

and a quicker action. The simple telegraph needle is light and well balanced on its axis, so that a breath of air would set it spinning, and is urged by a force just sufficient to turn it quickly; it can however make three signals, for it can turn to the right, to the left, or remain steady. The electro-magnet, on the other hand, can only show two signals, raising its armature or letting it alone, but it works at a distance with a force, which though very inconsiderable in itself (about sufficient to free the hair trigger of a rifle), is yet far greater than that of the needle, and it was therefore with this for their governing power that the printing telegraphs hitherto attempted have been constructed.

Now by the machinery about to be explained not only the electro-magnet but even the needle can be made to govern the motion of the heaviest apparatus, and thus in spite of the extremely small motive power of the latter we are enabled to secure the advantages that its variety of signals affords.

Having thus caused that certain mechanical effects should follow the movements of each separate needle we have next to contrive an apparatus by which these effects should be compounded together and then by it translated into letters, so that if three wires and three needles be employed in combination (no needle exceeding one movement for each signal) the apparatus we require is such that for each of their different combined signals, twenty seven in number, a different letter shall be printed. Now how all this can be done will shortly be explained. We shall see that in the *Telotype* the needles move as freely and as unencumbered by any restraint as if there were no machinery near them; but having once moved, and taken their several positions, slight rods are by an independent train of machinery allowed lightly to touch them. These touches last but for an instant, and the needles are free to begin another signal. There is no other connection whatever between the

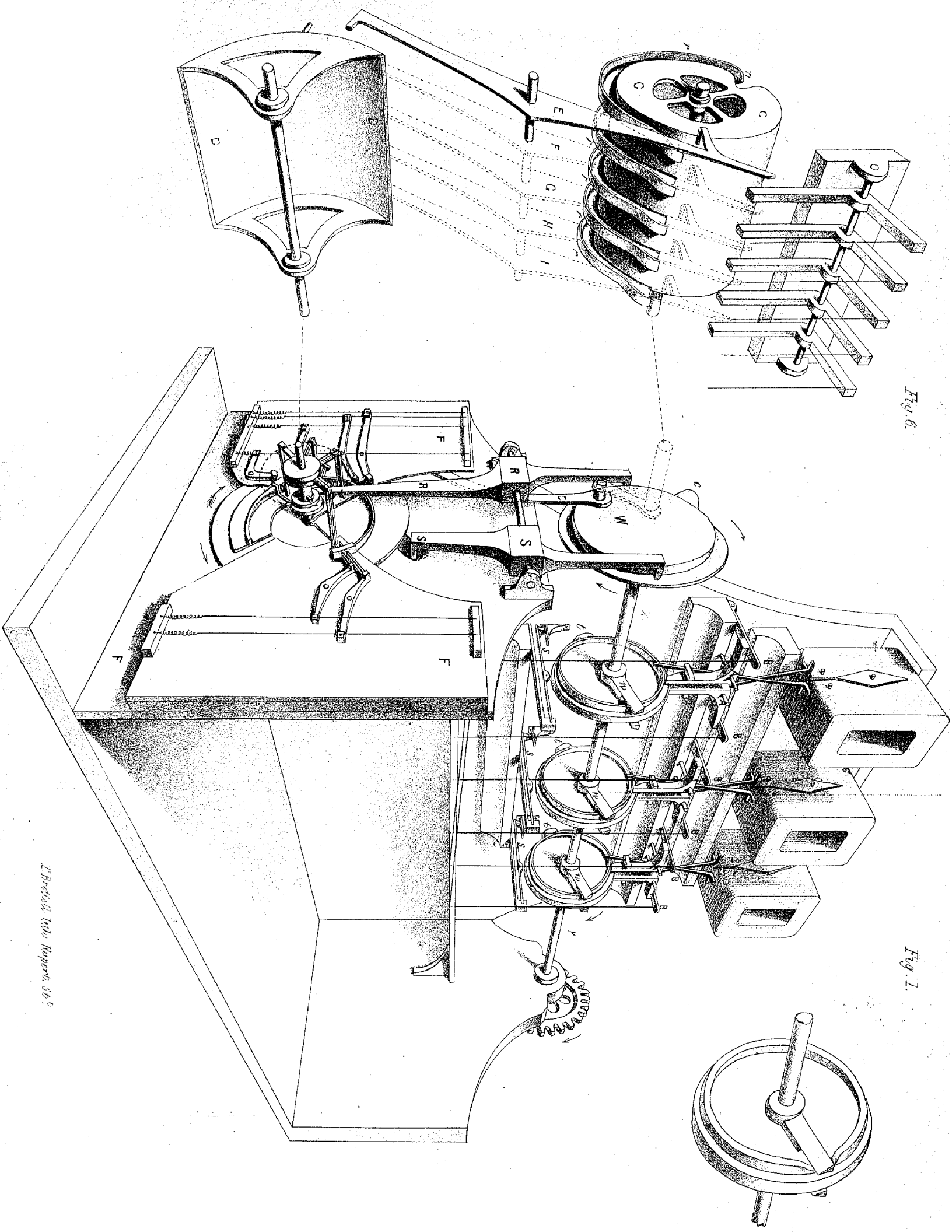

Fig. 6.

Fig. 1.

The Patent Office Reports, 56 p.

needles and the machinery except in these touches. They produce a change of position in the touching rods which is made mechanically available, and in the complete machine we have needles making signals on the one hand, and a type holder moving backwards and forwards on the other, the latter registering the signals combined together and transmitted to it from the former.

The description of the mechanism divides itself into three principal parts.

1. Part for enabling the weak movements of a needle to govern the movements of a heavy arm.

2. Part for making the movements of the needles thus transmitted result in the printing of letters, a different letter for each different compound signal.

3. Part for determining the proper movements of the needles for any given letter by touching a key.

It is in this order that we will take them, and we will first confine ourselves to the description of the simplest form of the Telotype. By doing so we shall gain a more concise notion of its general principles, and also avoid the evils of over crowded drawings. The symmetry of the machine is so complete that, when its principles are once clearly understood, there can be no difficulty of detail whatever, in adding parts to it so as to make it a more powerful and efficient instrument.

In Fig. I. the Telotype is represented; above are the galvanometers with their needles; beneath them are the touching rods; and to the axle X Y, upon which four wheels are fixed, a rotatory power is applied, which, moving as uniformly as we can contrive, works the whole machinery. The left hand wheel W carries a crank rod which influences another wheel below it, so that as the former revolves the latter oscillates backwards and forwards through an arc of about ninety degrees, being pushed forwards and left to spring backwards: round this the types are fixed, in front

are a series of slides whose action determine the movements of the type-wheel; S is the stamp. At each signal that the needles make, corresponding slides are moved, and they cause the type-wheel to be so arrested in its backwards spring as to bring a proper type under S, which descending, impresses it on paper.

There is a degree of uncertainty which attaches itself to all telegraphy, in that the needles are not invariably commanded by their batteries. The insulation of the wires is sometimes imperfect, so that the current will not pass to the distant station, and we cannot make the needles move at all; sometimes, again, the atmosphere induces currents of its own through the wires, and makes the needles move whether we will it or not. These are causes of error which cannot be eliminated by any mechanism, and we do not profess to be able in any way to get rid of them; all that we can do, by means of the contrivances here explained, is to ensure that whatever signals the needles may have given at a distant station shall infallibly be recorded, interpreted into letters and printed upon paper. Fortunately for us the causes of error that are specified above are scarcely felt at short distances, and it is for these, such as communication from one part of a town to another, that we feel our instrument to be especially adapted. Having premised this we will commence our description with that part which enables the weak movements of a needle to govern the movements of a heavy arm.

Referring then, again, to Fig. I. The needles are balanced so as to hang vertically when at rest, and to their lower ends a strip of card or of some other light substance is attached, which projecting down below the galvanometer coils, comes in reach of the touching rods. There are two of these touching rods in correspondence with each needle, and each of them is capable of turning through a small arc round an axis; they, like the needle, are balanced so as to

hang vertically when left to themselves, their lower ends rest on raised rings that are attached to the opposite surfaces of each wheel, and each ring has a notch in it. As the axle XY and its wheels turn together, the rods continue steady and their upper ends apart until the moment when the notches come upwards, and then they all move, their lower ends falling into the notches, and their upper ends falling through the paths of the strips of card. As the notch is but a small one, the instant after the rods have been left free to fall forwards they are forced back again. Now, if during this short interval of time one or more of the needles lie out of a vertical position, corresponding rods will have fallen against the cards attached to them, and will have been checked so that their lower ends will not have sunk into the notches. Hence the arms with wedge-shaped extremities that are seen projecting through the notches, and which otherwise would have passed over, will now get beneath them, and from their peculiar shape will, as they move on, lever the rods up high above the ring and then drop them again upon it as soon as they have passed away from under them. Thus those touching rods that were unchecked fall into the notches, those that were checked get levered high up, and both, as soon as the arm and notch have together passed by, find themselves on the ring again. It is the levering up of the touching rods by these wedges that supplies the method of communicating between the needles and the machinery. The needle acts as an inert body, by its position entirely. The force by which it has been urged into its position has nothing to do with the effect it produces on the machinery, and in this lies a fundamental difference between the methods we adopt, and those that have been hitherto employed. In all previous contrivances of this nature the dynamical force of the current has had not only to move an armature, but also to drag away a catch from the teeth of a wheel that was held back by it, but

the needle in the Telotype has perfect freedom of motion ; it is during its motion entirely disengaged from all connections, except, of course, the point or axis on which it turns, but it is after it has moved that it produces its effect. Again, the only delay caused by the addition of machinery to the rapidity of signalling is that corresponding to the time occupied by the notch passing under the touching arm, one evidently of very short duration. The force with which the touching arm is levered up depends entirely upon that with which the axis and wheels are made to revolve, and if the touching arms were strong enough they might be made to communicate with the slides of the machinery at once. As, however, they are made extremely slight, so as not in any way to hazard injuring the needles or their delicate supports by dropping against them, we must make them first communicate with thicker bars on partly the same principle that the needles communicated with them, that is to say, we must make them influence the thicker bars by their position. These thicker bars are the bent ones shown in the drawing and marked A ; they rest not upon the raised ring as the touching rods do, but on the flat surface of the wheel. One bent bar lies to the side of and turns on the same axis as each touching rod. The distance between the lower ends of the rod and bar is a little less than the width of the wedge, and again the thickness of the wedge must be a little greater than its height above the wheel. Lastly, towards the lower end of the bent bar a hook is fixed so as to overhang the touching rod, and almost be in contact with it when that rod is resting upon the ring. Hence, if the touching rod be levered up higher than the ring, it lifts the bent bar off the wheel, and it follows from the proportions above assigned to the wedge, that immediately before the touching rod has travelled to its highest peak, the bent bar will have been lifted up on to a level just above that of the lower point of the wedge, which itself will at that moment have

passed beneath it. The next instant the touching rod will be dropped and the bent bar alone will remain on the wedge, and it, in its turn, will be levered up still higher, and then dropped behind it, just as the touching rod had been before. Now, the bent bar may be very much heavier, and therefore stronger than the touching rod, and can in consequence be employed without danger to convey a much more powerful impulse from the wheels to the machinery than it could. All that has to be attended to is, that the touching rod should not be strained in being made the means of prising the bent bar on to the wedge. When once the touching rod is dropped it is out of the way of all injury, and the bent bar may immediately commence performing its duty. Thus, referring again to the drawing, we see levers B B pivoted at their further end, and resting upon a bracket; each lever lying across and just above the end of the horizontal part of the bent arms A A, its height above them being so adjusted that directly after the touching rods have been dropped by the wedges, and the lower ends of the bent bars have been levered a short way up by the wedge, the bar and lever shall come in contact, then the wedge passing further on, the bent arm moves higher, and the lever is lifted, and, lastly, the bent arm is dropped, and the lever drops also. By these means, as the wedge moves quickly by, a short impulsive movement is given to the levers, and by them, through the medium of the strings that are seen fastened at their ends, to the slides.

It therefore clearly results from all this that, there being two slides corresponding to each needle, according as any one of the needles has moved to the right, to the left, or has remained still, so shall one or the other or none of its corresponding slides be moved also.

It is evident that not only one, but a series of two or of any number of bars might be interposed between the needle and the lever, each bar increasing in massiveness and

strength. One however is amply sufficient in the present instrument.

The touching rods are as light as they can be made consistently with anything like stiffness. The cross pieces that are attached to the top of them are, the one to fall against the strip of card, the other to prevent the card from ever, by any accident, getting behind them when they have fallen forwards; if they did so, the apparatus would of course be put out of order. The addition of the bent bars creates no delay whatever in the rapidity of signalling; each particular signal is delayed a short time by it, but signal follows signal as fast as if no bars at all were there. Exactly the same number of signals, for instance, can be made in a minute with them, or with any series of them, as without them; but in the latter case the whole communication is of course delayed, though for a perfectly immaterial space of time.

If we choose to employ a long series of arms on this principle, we see the signals made by the needles travel through them in a manner not unlike that in which messages do from Semaphore to Semaphore in the old system of telegraphs. The signal is taken up by each arm in its turn, and each having forwarded it on to the next, falls back to its place. The last arm moves as fast as the needle does; but at any one instant the movement of the last arm will have no reference to the signal which the needle at that time is employed about; it will correspond to one that had been made some time before: so the delay incurred by using a series of arms tells, once for all, upon the whole communication and is not repeated at each signal. And as the last arm does not begin to move till two or three seconds, perhaps, after the needle has begun signalling, so it will continue moving after the needle has stopped, making up its arrears.

It is very interesting to watch such a series in operation; how the delicate, scarcely perceptible touch of the first arm

causes an influence that travels on, almost as if by instinct, through the whole series; how each arm hands it to the one beyond it, its available power increasing at each delivery.

With this we conclude the first part of the machine—namely, that whereby the needles are made to communicate with heavy mechanism; but before proceeding to the next division of our subject, we must explain the method whereby we inform ourselves of the exact time when in the distant machine the notch comes under the touching rods.

If the distant machine revolved with perfect uniformity, or if by any separate galvanic contrivance a wheel by the side of the operator was made to work in exact relation to the *Telotype* at a distance, the problem would be solved; but the last plan is cumbersome and the first impracticable, and therefore we are reduced to other methods. On the edge of each wheel we fix a tooth, *t*, and below each wheel, screwed to a bracket, is an arm holding a spring, *s*, bearing a metal point and pressing it against a metal plate. The circuit that passes round each galvanometer passes also between the metal point and plate, so when the tooth by means of the revolution of the wheels comes upon the spring it presses it down and breaks the circuit, and the operator at a distance, although still making contact with his battery, sees those needles before him that have moved swerve for an instant from their several positions. The eye readily detects this motion, although it be very slight and of short duration, and information is thus conveyed of its being time to commence another signal. The tooth is so adjusted as to press on the spring the instant the touching rod is above the notches.

We have now to avail ourselves of the movements of the slides, and to contrive that each different combination of them, not more than one slide out of each pair being moved, shall result in a different letter being printed. A crank rod

C is attached by a pivot to the face of the left-hand wheel, marked W in the figure ; the top part of it only is distinctly seen above the framework, and its further course is partly shown by dotted lines ; but in Fig. II. it is represented much more completely. Fig. II. represents the same part of the apparatus as that which is seen at the bottom of Fig. I., more or less covered with other mechanism that has reference to the movement of the slides. They are both of them supposed to be viewed from the same point of sight, but Fig. II. is magnified to double its size, in order to show more clearly its several parts. By referring then to Fig. II. we see that the lower end of the crank rod is pivoted on to an arm, R, the length of which is so chosen with reference to the radial distance of the first pivot from its centre, that when the upper wheel revolves the arm below oscillates backwards and forwards through an arc of ninety degrees, or thereabouts ; in front of this arm, and fixed to the same axle about which the arm itself moves freely, is a wheel, from behind which a point projects at the place marked *p* in Fig. II., and this wheel is urged by a spring which cannot be seen in the drawing, but the direction of whose action is indicated by the feathered arrows. Hence, as the arm oscillates up and down, the wheel alternately is pushed forwards in the direction of the plain arrows, and is left free to follow it by springing backwards in that of the feathered arrows. The axle to which this wheel is fixed is supported to the left by a bar that could not be shown in either of the drawings, and to the right by the main piece of framework marked F seen in the front of Fig. I., and which lies immediately behind the wheel and the arm that works it. The axle is prolonged just through this plate, and at its end a segment of a thin brass wheel is set of about one-third greater radius than the wheel of which we have just been speaking ; it is partly seen in Fig. II., is shaded and marked T ; this segment of a wheel T is divided into twenty-seven

FIG. 2.

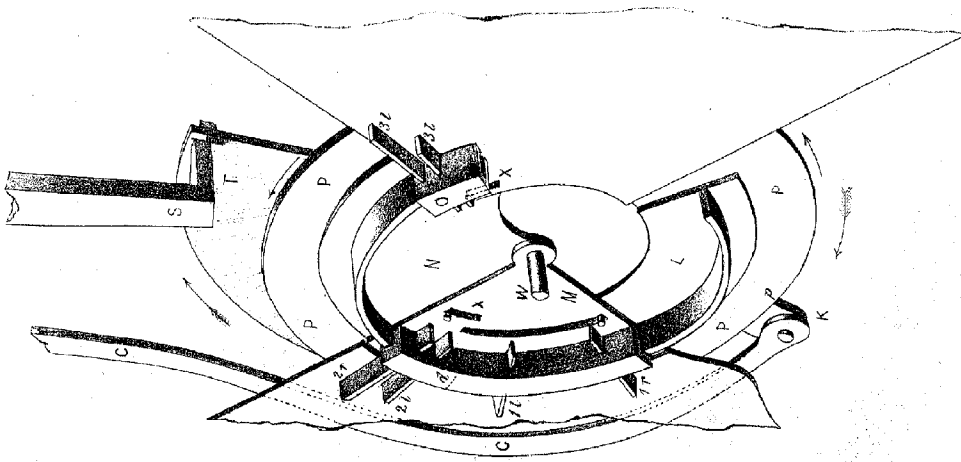

FIG. 3.

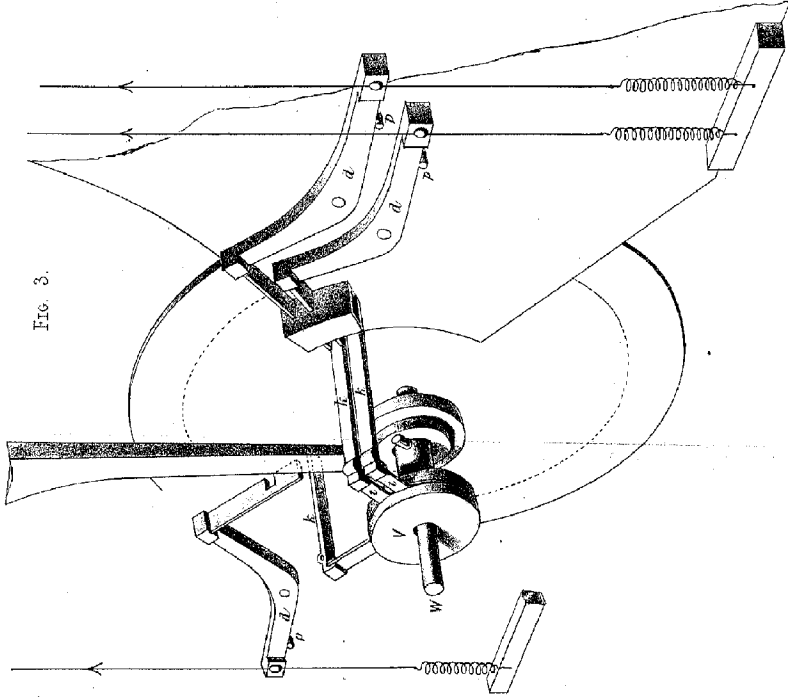

FIG. 5.

	are taking their positions	are taking their positions	are taking their positions
Needles	remain at rest	remain at rest	remain at rest
Touching Reeds	remain at rest	remain at rest	remain at rest
Remain- ing Slides Backwards	remain at rest	remain at rest	remain at rest
Slide XY with wheels, remaining uniformly move.	move up	move down	move up
Stamp	remain at rest	remain at rest	remain at rest

radiating strips of equal size, at the lower end of each of which a different type is fixed, and each strip is of such a size that the circular angle between the centre of the first strip and that of the twenty-seventh shall be a little less than an arc of 90° . Lastly, a stamp S is disposed as in Fig. I., a tooth from its lower end protruding through a hole in the framework, and lying immediately above one or other of the circular row of types. As the wheel W revolves, a tooth attached to the rim of the upper half of it, and which is partly seen in the drawing, and marked *c*, once in each revolution forces up the upper end of the stamp, and causes the tooth at the lower end to press down upon one or other of the types, according to which of them may happen to be beneath it at the time. Hence the tooth being placed with reference to the pivots of the crank arm as shown in the drawing, when W revolves the type wheel T is pushed forward to its full extent, bringing every one of the twenty-seven types in succession under the stamp S, and is then left free to move back again under the influence of the spring alone, and lastly the stamp descends upon its first type. Now if the plate were prevented from springing back its entire distance the stamp would descend not upon the first type but upon some other one. The object we therefore have in hand is to show how each different possible combination of movement of the slides, not more than one out of each pair acting at the same time, or in other words, how each different possible combination of simple signals that the three needles can give shall cause the stamp to descend upon a different type. This is effected on a principle of aggregate or compound movements. The slides in connection with the first needle cut off respectively one-third and two-thirds of the entire distance through which the type wheel is able to spring back, those in connection with the second needle, by an action quite independent of the first, cut off respectively one-ninth

and two-ninths of the entire distance, and similarly those in connection with the third cut-off one twenty-seventh and two twenty-sevenths of the same. Now suppose no needle to act, the plate and type wheel fly back as far as they can and the stamp descends upon the first type; next suppose the third needle to move to the right, the plate is stopped one twenty-seventh short and the stamp descends on the

First Needle.	Second Needle.	Third Needle.	Distance cut off in twenty sevenths.	Type on which the stamp descends.
o	o	o	0	1
o	o	l	1	2
o	o	r	2	3
o	l	o	3	4
o	l	l	4	5
o	l	r	5	6
o	r	o	6	7
o	r	l	7	8
o	r	r	8	9
l	o	o	9	10
l	o	l	10	11
l	o	r	11	12
l	l	o	12	13
l	l	l	13	14
l	l	r	14	15
l	r	o	15	16
l	r	l	16	17
l	r	r	17	18
r	o	o	18	19
r	o	l	19	20
r	o	r	20	21
r	l	o	21	22
r	l	l	22	23
r	l	r	23	24
r	r	o	24	25
r	l	l	25	26
r	r	r	26	27
First pair of Frames.	Second pair of Frames.	Third pair of Frames.		Key depressed.

second type, if the third needle moves to the left for a similar reason the stamp descends on the third type. If again the second needle alone moves to the left one ninth or three twenty-sevenths are cut off and the stamp falls on the fourth type, if the second needle moves to the left and the third also to the left then three twenty-sevenths are cut off by the second needle and one twenty-seventh by the third (four twenty-sevenths in all) and the stamp descends on the fifth type, and so on for all the remaining combinations taken in order; to make this clearer a table is annexed in which the figure *o* of the first three columns signifies that that needle under which it stands has not moved at all, *l* that it has moved to the left, and *r* that it has moved to the right: but the words at the foot of the columns refer to a subsequent page. These aggregate movements are obtained by the following methods.

Out of a flat circular plate of metal on which is fixed a raised ring two segmentary pieces are cut, each containing an arc of rather more than ninety degrees, the

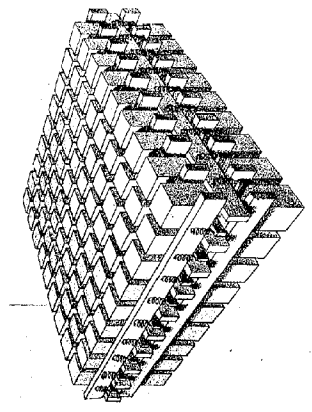

FIG. IX.

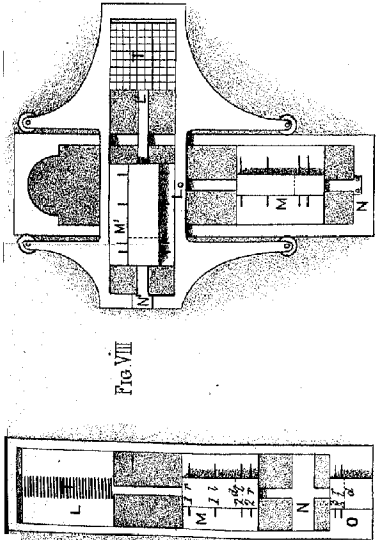
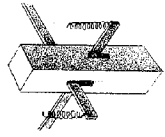

FIG. VIII.

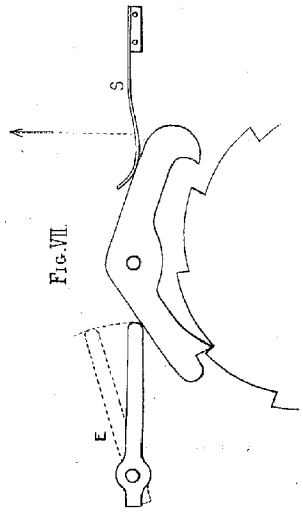

FIG. VII.

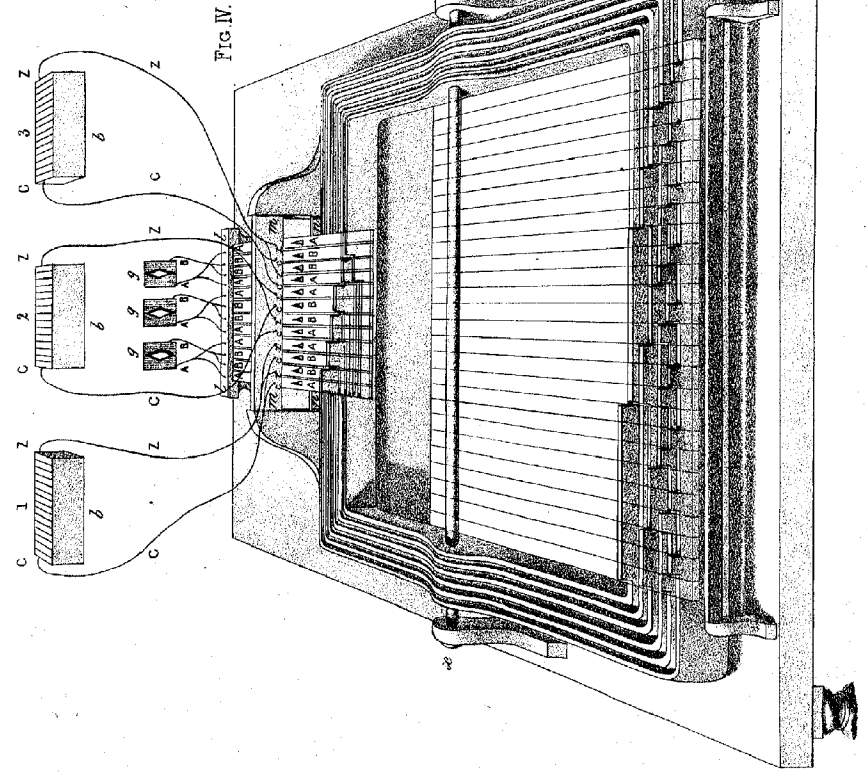

FIG. IV.

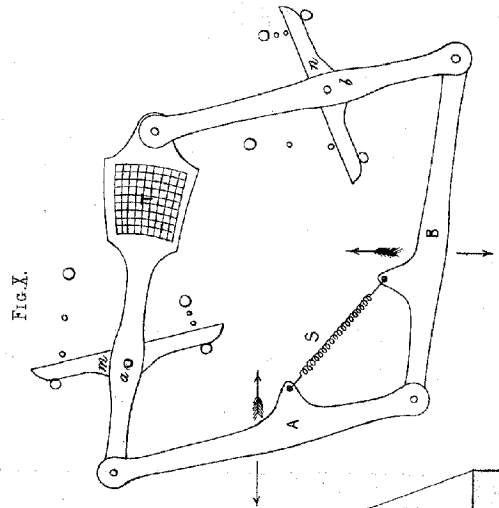

FIG. X.

J. F. Bredt, lib. Roper, S.

one piece L is little else than a piece of the rim with the ring upon it, and is fixed to P, the other piece N contains the centre of the circular plate from which it was cut and turns round the axis A while it lies flat upon P, hence N can be turned backwards and forwards about A until one or other of its edges come in contact with the corresponding ones of L. Lying upon both L and N and turning round the same axis A is another segmentary plate M, it has a broad ring running round it which is deeply grooved behind, in this groove the raised rings of L and N slide freely. Two slits will be observed in the flat portion of M, through which pins that are fixed severally to L and N protrude, these limit the motions of L M and N with respect to one another so as to prevent them from ever being pulled apart. Lastly, a grooved piece O in which the ring of N slides is fixed to the frame work, and there is an arrangement with a slit and pin between N and O connecting them together, but which however the perspective of the drawing partly hides. As the arm oscillates up and down the pieces L M and N are pulled out to their utmost and then left free to spring back again, L it will be recollected is fixed to P on which the spring acts, L therefore, connected as it is to P and to the type wheel, slides under and into M as far as the slit and pin allow it, then it carries M along with it and pushes it on to N, and then all three moving together N enter O. The action is very similar in principle to that of opening and shutting a common pocket telescope. Now the object of the three sets of slides is respectively to determine L's motion with regard to M, M's motion with regard to N, and N's motion with regard to O; this is easily done. First a diaphragm *d* indicated by dotted lines is fixed through the raised hollow ring of M, and also through O, this limits the action of L M and N, the slits being of course arranged so as to allow sufficient latitude of motion for the edges of the rings of L and M to reach the diaphragm; when therefore

R moves back P will follow it until L M and N have closed upon one another and upon O as far as these diaphragms permit, at this point P and the type wheel T stop, and the stamp S will descend upon a particular point of the latter, and that will indicate the position of the first type, it is the circular distance between this point and just behind that which lies beneath the stamp when M and N are pulled out to their furthest that has to be divided into twenty-seven parts. Across the raised rings of M and O run slides of the shape best shown in Fig. III., the notch in their bottom coincides with the section of the groove when the slides are pushed forwards so that the rings of L and M can run as freely as if no slides were there, but if any one of them be pushed backwards the groove is closed by it, and is blocked up as effectually as by the diaphragm *d*. This is the whole contrivance, the slides are numbered in Fig. II. according to the needles that severally act on them, thus *3l* means the third needle moving to the left. Hence, from *d* to *3l* and from *3l* to *3r* is one twenty-seventh of the distance through which P moves; from *d* to *2l* and from *2l* to *2r* is three twenty-sevenths, or one-ninth; and from *d* to *1l* and from *1l* to *1r* is nine twenty-sevenths, or one-third. An arrangement of this sort works with extreme lightness and precision, the adjustments are very simple, for the face of any slide where the raised ring is liable to come against it can be filed until the distances are quite right; and lastly, the slides are very strong and simple, and cannot get out of order.

The method by which the slides are worked is shown most clearly by the diagram Fig. III.; the slides there represented are *3l* *3r* and *2r*; one end of each crank *d* is attached to a thread that reaches it from A; a spring at the lower part of this thread keeps the crank pressed against a limiting stop, *p*; when the thread is pulled the crank pushes the slide, when let go it springs back to its limiting

stop. In order to replace it another crank, $i k$, works opposite; it turns round an axis W that moves in supports which are not shown, as they would hide the rest of the drawing. If now the arm of the crank, $i k$, be not rigid but a spring, then, if at the same moment an impulse is given both to it and to d , that spring will bend, and d will overmaster i , and the slide will be pushed forward. If an impulse be given only to i , then it will not bend, but k will push back the slide. Now a kind of reel, V , slides up and down the axis, in a groove round V all the arms i, i , lie. If then the reel V be depressed all the horizontal arms will also be depressed, and each crank will push back its opposite slide, unless an opposing crank d , pulled by its string, resists any of them, in which case these latter will not be pushed back but forwards, while all the others will be pushed backwards, the movement of the reel V is given by the rod R , which is worked by the same tooth, c , that works the stamp S . Now as R is on the opposite side of the wheel to S , then evidently inasmuch as S works at the moment that the arm K is at its highest, so R works when the arm K is at its lowest,—or in other words, when L, M , and N are pulled out to their utmost, and therefore when the slides are free to move. It must be remembered that at the commencement and completion of each movement there is a period of almost entire rest, quite enough so to allow of a quick impulsive movement, like that of the cranks, to act upon the slides. It will also be evident that all their mechanism offers no hindrance to the rapidity of making signals.

The needles have not to wait until the signal they have just made has produced its whole chain of effects before they can begin to work again, they continue their movements exactly as though no machinery were near them. There are two separate actions going on—the needle moving, and the mechanism working, the whole time taken up by each complete needle movement being the same as that of each

complete mechanical movement, but they are contemporaneous, and not successive. The speed with which the axis is made to revolve certainly regulates that with which the needles may signal. But it can be made to revolve as slow or as quick within certain limits as we like. We, therefore, cause it to move as fast as the needles can with certainty and precision take their positions, the more uniformly it can be made to work the better, and we can of course choose any source of power we please to work it that we find convenient. The diagram Fig. V., gives a table of the movements of all these parts. No new method is here offered for the movement of the paper or the inking of the types; there are many plans well known to mechanics of doing all this, and we have here no other suggestions to offer on the point, but at the same time we must express our conviction that these methods admit of very considerable improvement. We here close the description of the second division of the machine, namely, that whereby the movements of the needles, having been first transmitted to machinery result in the printing of letters, a different letter for each different compound signal, and it remains for us to show how we can determine the proper movements of the needles for any given letter by touching a key.

Fig. IV. represents this apparatus. On an axle $x y$, six frames, one within another, are capable of turning through a small angle; upon the same axle twenty-seven keys like those of a pianoforte also turn, and they each are intended to bear a different letter. In Fig. IV. their outlines alone are shown in order that the arrangement of the frame-work beneath them might be seen. Now each adjacent pair of these frames refer to a different needle, the first pair refer to the first needle, the second pair to the second needle, the third pair to the third needle; we contrive that the first of each pair on being depressed in front shall move the needle corresponding to it to the left, and we will, therefore, dis-

tinguish the first of each pair by the letter *l*, similarly the second of each pair moves the needle to the right, and we will call it *r*, while if neither one nor the other of the pair be moved, then the needle they correspond to remains still; so that by depressing not more than one out of each pair of frames, and by doing so in every possible manner, we command all the twenty-seven different needle signals. It will be seen in Fig. IV. how this is effected; properly arranged teeth stand up immediately beneath the keys and in contact with them, so that on any one key being touched only those frames are moved whose teeth are in contact with it. It will also be observed, by examining Fig. IV., that there the combinations are all gone through in order, so that on referring back to the table, page 14, and considering the contents of the columns to refer to what is written at the bottom of them, the effect of each key, as shown in Fig. IV., will be found there expressed; and by further inspection it will be manifest, that the result of depressing the first key, counting from the right hand, is that the first type shall be printed from, that of depressing the second the second, the third the third, and so on.

The way in which the necessary contacts are made is shown at the back of Fig. IV. Twelve metal springs, insulated from one another, are fixed to the bar *l l* and each spring has two metal points that are fixed opposite to one another, the one on the top of the spring and the other on the bottom of it, this latter is of course hidden by the drawing. A metal bar *n n* lies beneath these lower points, and a wooden bar *m m* which has metal tablets let into it lies above the upper ones, so that each spring when left to itself rests upon *n n*, but when pushed up about the eighth of an inch its point pushes against *m m*. Now *b b b* are supposed to indicate the batteries and *g g g* the galvanometers; wherever the letter C is found, the part it stands on is connected with the copper plate of its battery, and simi-

larly Z with the zinc plate ; in the same way A refers to the left-hand wire of the galvanometer, and B to the right-hand one. The first four springs refer to the first galvanometer and battery, the second four springs to the second, and the third to the third ; considering then, any one of these sets of four springs each, if no one of the four be touched, then, lying as they all do in contact with the metal bar *n n*, A and B will obviously be in metallic contact. If however the left-hand pair be pressed against *m m*, and the right-hand pair be just lifted off *n n*, A will be put in contact with C, and B with Z ; but if on the other hand the right-hand pair be pressed against *n n*, and the left-hand pair be just lifted off *m m*, then A will be put in contact with Z, and B with C. All therefore that we have to do is to contrive that the springs in each set shall be so lifted when the frames corresponding to them are depressed in front by the keys, and this is done by filing away every portion of each frame that could possibly come in contact with the springs, leaving only a high tooth under those springs that it has to press against *m m*, and a low tooth under those which it has just to lift off *n n*. Hence, by depressing the first frame the first needle is moved to the left, by depressing the second frame the first needle is moved to the right, by depressing the third the second needle is moved to the left, and so on as it should be.

We have now sufficiently explained the essential parts of the Telotype, the description of them, like that of all other mechanism, is necessarily tedious, yet the conception of their action, when once clearly understood, is extremely simple. The instrument itself presents little or no difficulty of construction, there are no accurately fitted parts, no delicate adjustments in it, nothing in fact that requires superior workmanship ; indeed the Telotype appears to belong peculiarly to that class of machines that are themselves readily made by machinery. Here then we end our description of its

simplest form, it remains for us to explain certain additional parts which may or may not be used, but which if employed increase very considerably the efficacy of the instrument. They are as follows :—

Part for commanding a larger number of types than there are simple signals of the needles, so that on certain pairs of signals being made a third and a different letter shall be printed.

Part for determining that on making certain signals no letter shall be printed, but a mechanical effect shall be produced which may be applied as we will, to ring a bell, and so forth.

Part for regulating the movements of the paper carrier so that the printing may not be disconnected owing to the use of the above parts.

Part for enabling communications to be carried on in cypher, so that, two machines being adjusted according to the letters of a key word, messages may be signalled and printed as usual between them, but which shall appear in cypher at every other station.

Suggestions for enabling two needles to perform very nearly the work of the three in the manner they are employed above.

We have shown how by using three wires and three needles we can obtain command over twenty-seven different types, and this is certainly *sufficient* for most purposes, but it would vastly increase the perfection of the machine if we had at our disposal more of these. We want fair typography to convey our communications in, we want capital as well as common letters, we want commas, full stops, notes of interrogation, and so forth, we want the numerals, and, besides these, certain contractions would be very convenient. It is true that we might select say two signals out of the twenty-seven, which we will call respectively *u* and *v*, and agree that they should have no real meaning in them-

selves, but should change the meaning of the letter that was printed next after them; so that, for instance, the two successive signals u, a , should stand for and represent A, u, b , should represent B, and so on; and, again, that v, a , should represent 1; $v, b, 2$, &c.; but this would be a return to that symbolism which, in our instrument, we desire especially to avoid, and we will therefore explain a simple contrivance by which, when the two signals u, a , are made, A and nothing else but A shall be printed; when u, b , are made B shall be printed, and so on. Of course, if we employed a fourth wire, and added on a fourth wheel with its rods to the axle X Y, and a fourth sliding segment of a circle to L M and N, we should gain exactly as much in variety of signals and types as we should by setting aside the two signals u and v , and using two successive signals to indicate each of the extra letters; indeed there are cases where, from having to communicate through very small distances, as from one part of a large building to another, such a plan might be a very advisable one to adopt, but generally speaking, each additional wire is a very serious inconvenience, and, therefore, one that we should use every endeavour to make ourselves independent of. The delay caused by the use of two signals for each of the extra letters would not tell much upon the whole communication, as those letters are much the less common ones, but, on the other hand, the convenience of having them is very great, and much confusion would constantly occur did we not possess them.

Fig. VI. represents the contrivance: a cylinder C turns on an axis, which is supposed to join on by means of a crank to X Y: a segment of a cylinder D is fixed below to the axis W, which, it will be recollected, is attached to and turns together with the type wheel. Certain rods, E F G H I, exactly similar to one another, and represented as five in number, lie between C and D, and owing to their balance

their upper ends press against C, and their lower ends lie at a distance of about one-sixth of an inch apart from D. We have at present only to concern ourselves with the two left hand ones, E and F, the others, though acting just as they do, are used to fulfil another purpose. Along the cylinder C runs a notch *n*, and round the cylinder are rims *r r*, of the shape shown in the drawing. Hence the bent ends of the rods E F, when the notch comes round, would naturally fall into it, and then emerge out of it on the opposite side, on to the surface of the cylinder; but if either E or F be prevented from falling into the notch, then the rim *r* will pass beneath it, and the rod will lie upon the rim.

Now the motions of D being exactly the same as those of the type wheel, let there be two studs fixed upon D, so that when *u* comes under the stamp S, one of them comes under the arm E, and when *v* comes under the stamp S, the other stud comes under the arm F. Again, let the notch be so placed as to come under the upper ends of E and F, at exactly the same moment that the stamp falls. Hence E and F fall at the same time that the stamp does; and if either *u* or *v* have been signalled, then E or F, as the case may be, falls upon the stud and is checked by it, and in consequence gets forced up on to the rim. If any other signal has been made, both E and F will fall freely, and emerge from the notch, not upon the rim, but on the surface of the cylinder. Now the rims are continued concentric with the cylinder, about half-way round its circumference, and they end by turning upwards abruptly, forming a kind of a cam tooth, so that the instant that R is jerked by the tooth *c*, that same instant E or F, if either of them be upon the rim, will be jerked up also, and will act upon slides that move across an additional sliding segment of a circle to L M and N, and which we will call K, on exactly the same principles that the bent arms A A do, and of course at

precisely the same time as they. The slides in K must lie apart from one another, at a distance one-third of that at which those of O lie, and by these means we obtain command over eighty-one different types, the extra fifty-four lying in pairs between each adjacent two of the original twenty-seven. To admit of this arrangement, the type-wheel and all the sliding segments should be increased exactly threefold of what they were obliged to be before, so as to give adequate room for the row of types and for the working of the slides: *u* and *v* are of course blank; no letter is impressed on the paper when they come under the stamp, their office is simply to cause the slides of K to work, and thus to influence the next letter. If the types lie thus in order: *a* A 1, *b* B 2, *c* C 3, and so on; and if *u* influences the slide nearest the diaphragm of K, and *v* influences the other, then evidently if we make the successive signals *u a*, A and A only will be printed; if *v, a*, I will be printed; if *u, v, B*; and so on.

We have now to show how that on making certain signals different mechanical effects can be produced, which may be applied to what purposes we will, and this is a power that we shall find to be very convenient, and to a degree even necessary. The rods G H I, a greater or less number of which might be employed, fulfil this end; for let studs which we will call respectively *g, h, i*, be fixed in such a manner upon D, that when the signals, say *v x, v y*, and *v z* are made, *g, h* and *i* shall severally come beneath G, H and I, which will fall upon and be checked by them on precisely the same principles that we have employed to work E and F; the strings that are attached to the arms above G, H and I, will therefore be pulled, and these will produce the required mechanical effects. By altering the shape of the rims we can obviously determine when and for how long, within certain limits, these actions shall occur and last so as to answer the desired ends. This contrivance

can be employed to regulate the movements of the paper when compound signals are employed, for without some express regulator the paper, always moving one step for each signal, would cause in these cases a defect in the typography, as each new letter would be preceded by a space. We therefore fix beneath G not one but a row of studs, one corresponding to each new letter; hence, whenever *u* or *v* is signalled, the string in correspondence with G gets pulled, and by altering the shape of the rim from that shown in the drawing to one in which it shall rise to its full height immediately after quitting the notch, and then continue concentrically with the cylinder almost round to the notch again, the string will be pulled directly after the signal *u* or *v* has been made, and will continue stretched during the whole space, or nearly so, of one complete revolution of C, or that of one complete signal. Now, whatever plan may be employed for governing, generally, the movement of the paper carrier, let the method by which the power is applied be one which will admit of that movement being stopped without stopping the whole machine, and also let the catch by which it is permitted to move on step by step be like the one represented in Fig. VII. In this drawing Q is a rigid arm moving up and down once during each signal, and S is a spring that presses upon the detent; when then Q is lifted S urges the detent to follow it, and when Q descends it forces the detent back again, thus permitting the wheel that works the paper carrier to advance one step. Now if S be removed from off the detent, then when Q is raised the detent will not follow it, as there will be no spring acting to compel it to do so, and the paper carrier will accordingly remain still. A string is therefore attached at one end to S, and at the other to the rod above G, so when *u* or *v* is signalled the paper will advance one step, but when the next letter is signalled the detent refuses to work, and it will not advance another, and so the type

descends where it ought to do, namely, on the space next adjacent to the letter that was previously printed. There are certain exceptions where it is advisable that the new letters should be preceded by a space, as in the case of capital letters, which beginning a word, require a space before them, and therefore in such instances no provision of this sort need be made.

The signal corresponding to *o, o, o*, should stop the paper carrier, so that when no message is passing the paper shall remain still, and we further require a blank type to put in the blanks between the words. These two, added to *u* and *v*, will together subtract four out of our twenty-seven simple signals, leaving us twenty-three for the immediate purposes of printing.

If the wires on leaving the contact keys were, any of them, crossed thus $\overset{a}{\text{---}} \times \text{---} \underset{b}{\text{---}}$ it is obvious that signals passing through them would appear totally different at the distant station to what they were at the near one; but if the wires were again crossed (re-reversed) at the distant station, then the signals would be put right again and become intelligible. In this way two telegraphs might evidently correspond freely with one another, while an interposed telegraph could not understand the messages that were conveyed through it. Now, supposing we use three galvanometers, and if the state of the currents passing through the uncrossed wires be indicated respectively by the letters *a b c*, and if when passing through crossed wires by the letters *a' b' c'*, then the different possible ways in which the currents sent through them could be modified by crossing, would be as follows, seven in number, or eight possible states in all:—

<i>a b c</i>	<i>a b' c</i>	<i>a' b c</i>	<i>a' b' c</i>
<i>a b c'</i>	<i>a b' c'</i>	<i>a' b c'</i>	<i>a' b' c'</i>

and with reference to these we must make our apparatus. Now, if we have a table like that represented in Fig. XI.,

with strips of metal so fixed into it that in each pair of lines those strips that are shaded are in metallic communication with each other, but otherwise insulated, and likewise those that are left white; and if each wire be divided in two and their ends attached to metal points, which press upon the strips along the lines, mm and nn , that is to say the six ends of the wires on the left, $A_1 B_1 A_2 B_2 A_3 B_3$ pressing along the line mm , and those to the right $A'_1 B'_1 A'_2 B'_2 A'_3 B'_3$ along nn , then obviously by pushing the slide backwards and forwards we can variously modify the connections between each of these pairs of wires and ensure any one of the eight different states, mentioned above, being assumed. Thus if we push the row of letters abc up to the index none of the wires are crossed if the row def , then the connection of the wires, are those represented by the letters abc' and so on; so suppose k to be chosen as a key letter, then the cypher-slides are pushed up till that letter comes beneath the index point at each of the communicating stations, the instruments then become *en rapport* and the signalling can proceed as usual, though unintelligibly to intermediate stations. Eight changes are, however, far too few for effectual secrecy, and we must, therefore, complicate our machine by using not a single "cypher-slide," but four or five, placed respectively along the sides of a prism, with an equal number of sides. These cypher-slides are, of course, to be differently adjusted. We take any word as a key word, say "Telo-type." Then the first slide must be pushed up to the row of letters in which t lies, the second up to that in which e lies, and so on till the cypher slides are all exhausted. This prism is urged to revolve round its axis by a force, but is held back by a detent, which lets it escape at the moment which elapses between the close of one signal and the commencement of the next, in fact, during the time that the tooth on the side of the wheel w breaks contact. This

catch is, of course, worked by the Telotype machinery at the distant station, but by the keys at the near one. One cypher-prism is sufficient at each station, as the detent can readily be placed so as to be worked at pleasure either by the keys or by the machinery. The contact points are raised off the slides during the time that the prism is actually in motion by any simple contrivance as that in Fig. XIII.

We are compelled to combine with this a second apparatus so as to obviate the possibility of the communicating machines getting *hors de rapport* with each other. We must have a simple signal which, when made, shall readjust both cypher prisms by bringing them round to their starting points whenever we please. This is easily done by the apparatus, Fig. XII. W is the catch wheel, t an arm fixed on to the face of it; d the detent, $p p_1 p_2$ are limiting stops standing out from a frame work, $c c_1 c_2$ are centres of motion round which the arm that works the detent, W , and also a large V shaped arm, that itself carries the detent, severally turn; this latter is pressed by a spring against p . If Q be not raised the detent works exactly as if Q were fixed, but if it be raised up to p_2 then the detent clears W and the tooth on the lower arm of Q checks t as it and the wheel run round; on lowering Q again the detent acts as before, but the prism has been brought back to its starting point. Now the signal that produces the mechanical effect of raising Q (by means, of course, of the mechanism described p. 24) should be blank, so that if we use it occasionally instead of the ordinary signal for putting in blanks between words, no time whatever is lost by employing it. Lastly, as to the best number of cypher slides to use. If we have two, there are 8×8 or 64 different ways of adjusting the two instruments; if three, 64×8 or 512; if four, 4,096, or very near 5,000; and therefore, if five, 40,000. We should prefer this latter number; it is to all practicable purposes *perfectly* secure, while four slides would hardly be so. We have

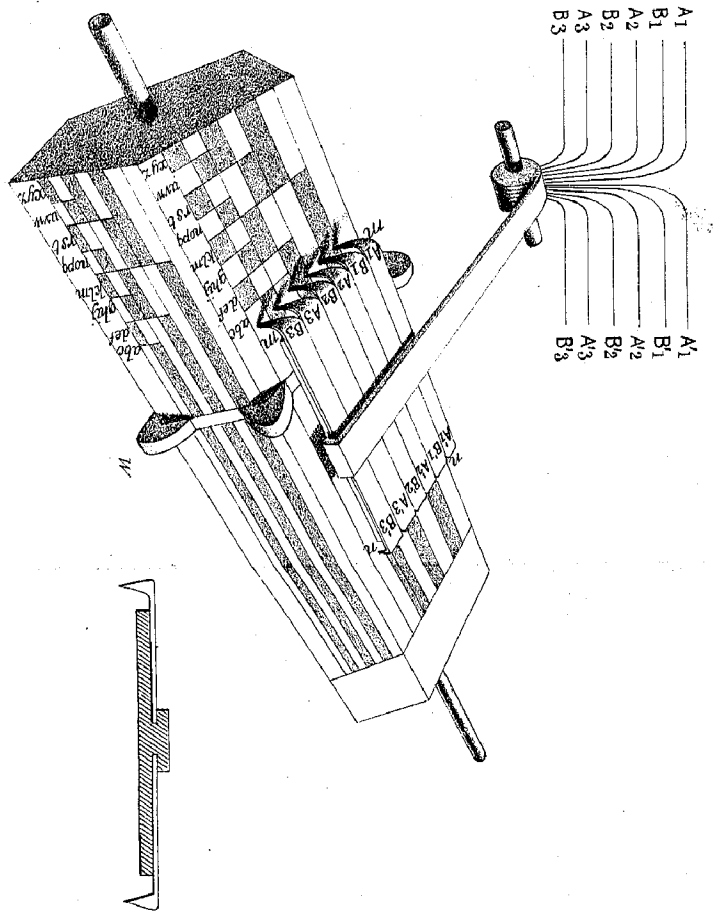

Fig. XI.

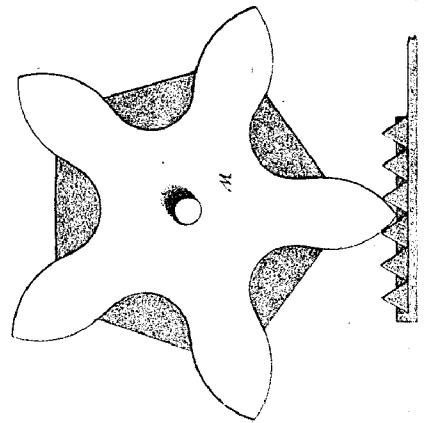

Fig. XIII.

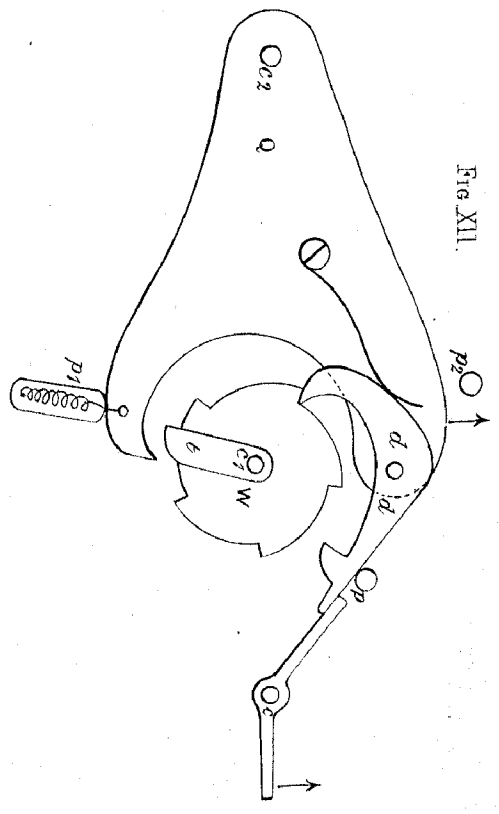

Fig. XII.

therefore represented Fig. XI. as working a prism with five sides.

A very important question remains to be considered, it is whether in actual telegraphy two needles could not be made to do the work of the three in the manner they are employed above. The method we propose is one that appears to answer extremely well, but considerable experience would be required to decide whether the chances of error that it introduces would not more than counterbalance its obvious advantages. It consists in using two battery strengths for each needle, the one just sufficient to turn it freely, the other enough to make it move not only itself, but also a second light rod swinging by its side, and which itself is touched by touching rods that are made to work slides. It is quite unnecessary to give a drawing of the Telotype thus modified, as it is perfectly easy to conceive the instrument. Each needle will thus give five signals, one to the left, one strongly to the left, one to the right, one strongly to the right, and one still; and thus with two needles we obtain command over twenty-five signals, which is quite sufficient. The sliding segments would be reduced in number, O is not wanted, and N is fixed, there would be four slides on each side of the diaphragm in M; and those on the one side would be five times the distance apart that those on the other side are. For making contact eight frames would be required instead of six, and other obvious modifications would have to be made. Before telegraphing, we should find out by trial and then set apart the number of plates that would just be sufficient for the weaker battery, and use the whole of the battery plates for the stronger one. We sincerely trust that experiments will be made upon this point, which, though but shortly treated of here, is yet one of the most important.

With this our description of the Telotype ends, it remains only for us to offer a few additional remarks on the

subject of compounding signals. There are many methods besides that described in Fig. IV. of doing this, it was given not as the one necessarily best in itself, but rather as that whose accompanying mechanism seemed most calculated to be represented in a drawing. Other methods are certainly simpler in themselves, but the machinery that works them is in those we have constructed too much involved to admit of the whole apparatus being exhibited in one single drawing. Now the sliding parts L, M, and N, instead of moving circularly round an axis, may be made to move as in Fig. VIII., between grooved rods in a straight line. And again to L another pair of grooved rods may be fixed cross-ways, between which a second system of sliding-parts L¹, M¹, and N¹ may also work. Hence a rectangular type-holder whose length is equal to the play of L¹, and whose breadth to that of L can have any part of its surface brought beneath a stamp that has been properly adjusted. In this way a great number of types can be packed in a small compass, and the play of the machine will be considerably diminished; thus, supposing each type to take up the sixth of an inch, then a row of an inch-and-a-half long would contain nine of them, and, therefore, eighty-one types could be packed into a frame only one inch and-a-half square. A good way of packing types is shown in Fig. IX. Each type is there fixed to the bottom of a separate rod, and the rods themselves fit into the square holes that are formed by thin bars crossing one another in opposite directions, these are ultimately secured by passing through the sides of a frame, but which for clearness sake, is not represented in the drawing. By these means the types are restricted to movements in a vertical direction; and to keep them suspended slits are made crossways in each rod through which thin bars pass loosely, one bar through each row of rods looking in one direction, and also one bar through each row looking in the other, and the bars themselves are sup-

ported by springs. Hence, each type is doubly suspended, so that if the support of only one bar be taken away, the type rod will, nevertheless, be kept in place. Now, if the stamp falls on one of these type-rods, it of course depresses it, and together with it the two bars by which it is supported, but obviously for the reasons just stated, no other type will be put out of place.

Such a type-holder is of course heavy, but it is very strong, and could hardly ever get out of order. There is however another method of impressing letters upon paper, namely, by punching the letters out of a thin sheet of metal, and inking the stamp, which is far lighter and more simple than the last one, but is difficult to be used without smearing the paper. If by any method this smearing could be avoided, a remarkably simple method of compounding signals might be employed, namely, that shown in Fig. X. It is only suitable to govern a light type bearer, as, from the number of joints in it, it would get strained by working a heavy weight; and, again, the type bearer being far from square, almost the only way of ensuring the right position of the types would be to punch them out after the rest of the machine had been completed, placing the punch in exactly the position that the stamp should itself occupy, and this is readily enough done when we have to treat with a thin sheet of metal. There is another advantage in the machine Fig. X., from its slides moving on fixed supports, it also works with the greatest precision, and its simplicity and lightness are great recommendations: A and B are two arms moving freely round the same axis C, to these other arms *a* and *b* are jointed, and again *a* and *b* are jointed together. To *a*, the type holder T is fixed. Hence the action of A is to move T backwards and forwards, that of B to move it up and down. We further compound the movements of the two ends of the bar *m* upon *a*, and that of *n* upon *b*, so that by using in all eight slides, and four diaphragms, T

can be placed in nine different positions reckoning sideways, and also in nine different positions reckoning lengthways, or in eighty-one positions altogether. There are other methods of compounding signals, but they do not appear to be so useful as those we have mentioned above, and, therefore, do not require further notice here.

If telegraphs, that worked and printed satisfactorily, were once found practicable, most large houses, public and private, would soon become supplied with them. The communication being so immediate, answer following question as fast as it is put, affords much more nearly the advantages of a personal communication than the best regulated post office ever could. Any scheme to introduce telegraphs generally, would probably be first confined to London. There would be central offices, and from these bundles of wires would radiate to numerous branch offices; from the branch offices again wires would pass along the adjacent streets, and supply houses as they passed. The expense of distributing wires in this way could not be extreme, for, if the branch offices were as numerous as the branch post offices now are, the distance that the wires to each private house would have to traverse would never be great.

At this point we will conclude these pages, the result of many experiments, and we offer them to the public in a firm hope and belief that the contrivances here explained will be found fully capable of subduing that subtle agent—Electricity, to the better service of man.

FINIS.

LONDON:

PRINTED BY T. BRETTELL, RUPERT STREET, HAYMARKET.